

O4H200

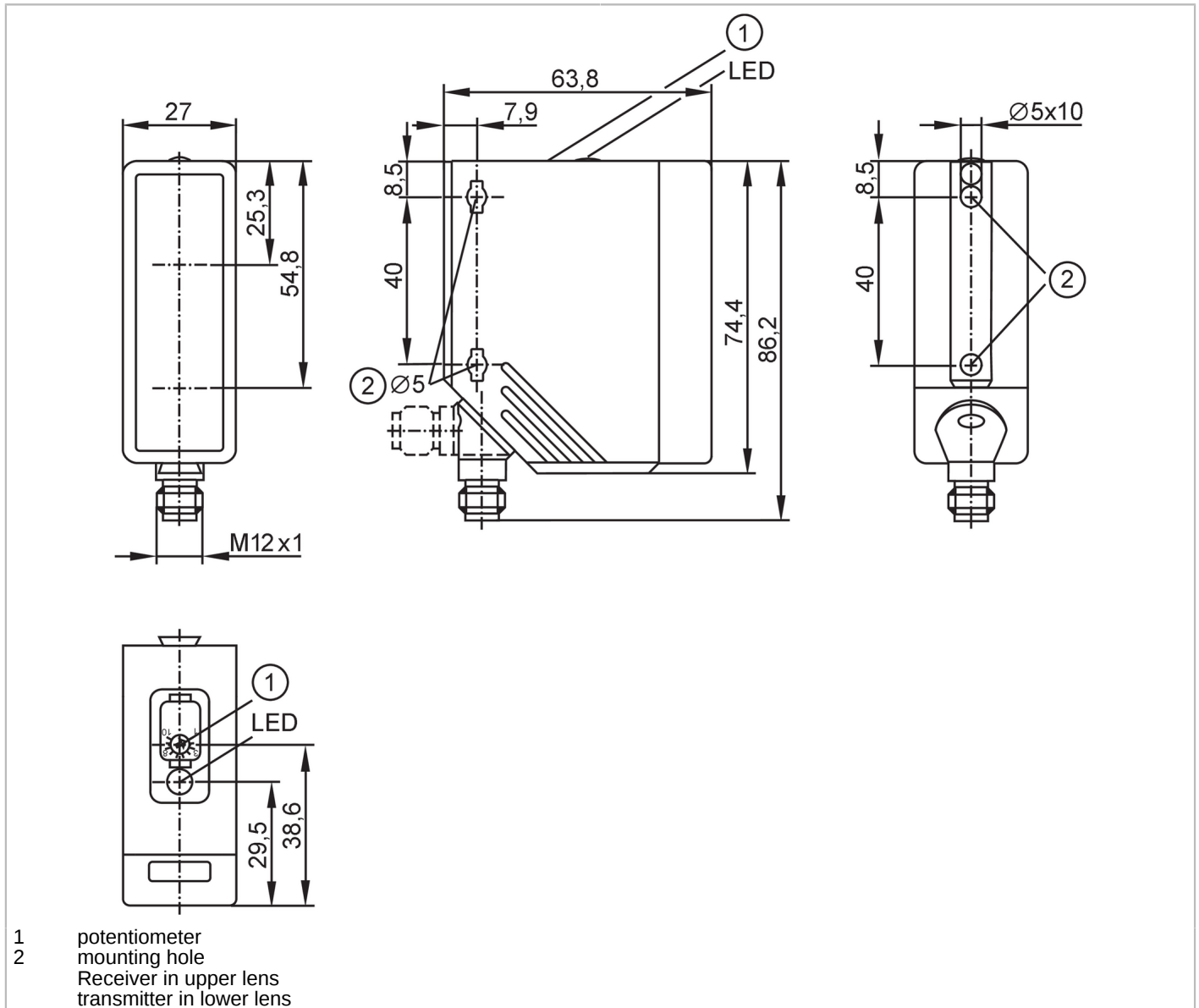

Diffuse reflection sensors with background suppression

O4H-HPKG/US100



Product characteristics	
Type of light	red light
Housing	rectangular
Application	
Special feature	Background suppression
Function principle	Diffuse reflection sensor
Application	Industrial applications
Electrical data	
Operating voltage [V]	10...36 DC; (cULus - Class 2 source required)
Current consumption [mA]	25
Protection class	II
Reverse polarity protection	yes

O4H200



Diffuse reflection sensors with background suppression

O4H-HPKG/US100

Type of light		red light
Wave length	[nm]	624
Outputs		
Electrical design		PNP
Output function		light-on mode
Max. voltage drop switching output DC	[V]	2.5
Permanent current rating of switching output DC	[mA]	200
Switching frequency DC	[Hz]	1000
Short-circuit protection		yes
Type of short-circuit protection		yes (non-latching)
Overload protection		yes
Monitoring range		
Range	[mm]	100...2000; (white paper 200 x 200 mm 90 % remission)
Range on white object (90 % remission)	[mm]	100...2000
Range on grey object (18 % remission)	[mm]	100...1100
Range on black object (6 % remission)	[mm]	100...700
Range adjustable		yes
Max. light spot diameter	[mm]	100
Light spot dimensions refer to		at maximum range
Background suppression available		yes
Operating conditions		
Ambient temperature	[°C]	-25...60
Protection		IP 65
Tests / approvals		
EMC		EN 60947-5-2
MTTF	[years]	326
Mechanical data		
Weight	[g]	121.5
Housing		rectangular
Dimensions	[mm]	74.4 x 27 x 63.8
Material		housing: PA; Front framework: stainless steel; operator interface: TPE / PC
Lens material		front lens:PMMA
Lens alignment		Side sensing
Mounting hole		
Tightening torque	[Nm]	< 2; (when using a mounting screw M5)
Displays / operating elements		
Display	Switching status	1 x LED, yellow
Operating elements		potentiometer

O4H200



Diffuse reflection sensors with background suppression

O4H-HPKG/US100

Remarks

Pack quantity: 1 pcs.

Electrical connection

Connector: 1 x M12; coding: A; Contacts: 4



Connection

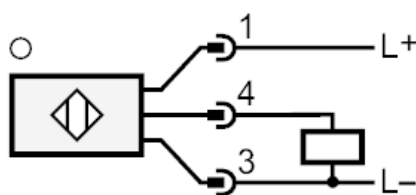

Diagrams and graphs

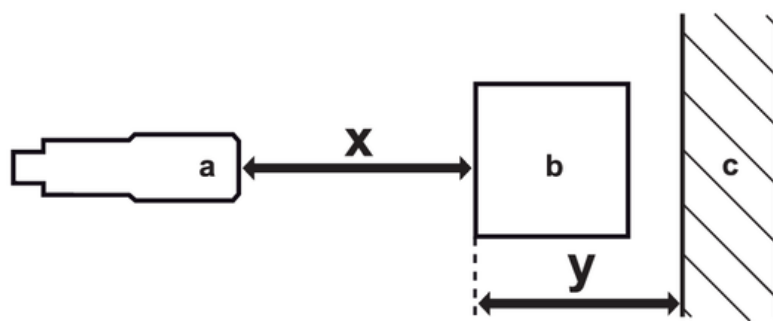

- a: sensor
- b: object
- c: background
- x: distance sensor/object [mm]
- y: min. distance object/background [mm]



Diffuse reflection sensors with background suppression

O4H-HPKG/US100

Background suppression chart

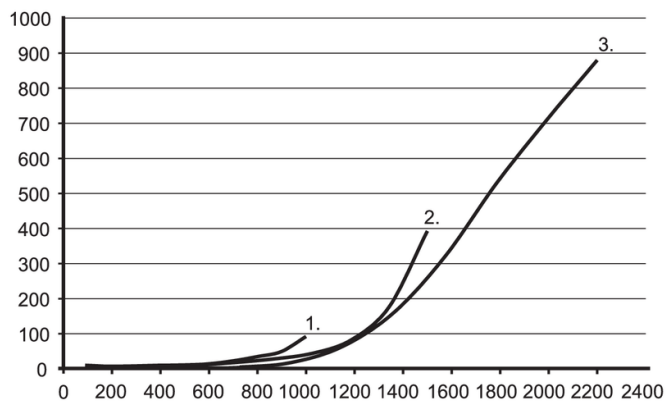

x: distance sensor/object [mm]

y: min. distance object/background [mm]

1 = object black (6 % remission) , Background white (90 % remission)

2 = object grey (18 % remission) , Background white (90 % remission)

3 = object white (90 % remission) , Background white (90 % remission)