

AC5215

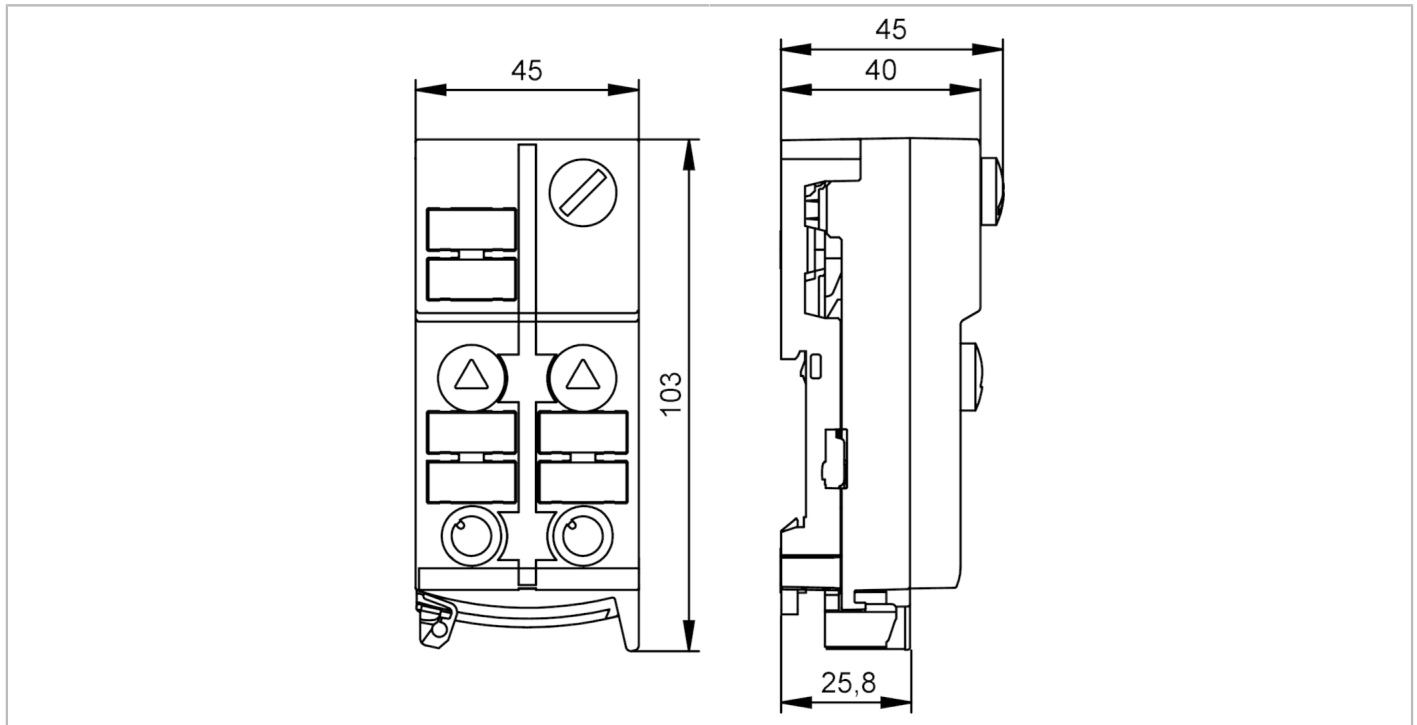

AS-Interface ClassicLine module with quick mounting technology

ClassicLine 4DI-Y IP67



Application	
Design	housing for DIN rail mounting
Application	field installation
Electrical data	
Operating voltage [V]	26.5...31.6 DC
Max. current consumption from AS-i [mA]	250
Inputs / outputs	
Number of inputs and outputs	Number of digital inputs: 4
Inputs	
Number of digital inputs	4
Input circuit of digital inputs	PNP
Sensor supply of the inputs	AS-i
Voltage supply [V]	18...30; (DC)
Max. total current rating of inputs [mA]	200
Input current High [mA]	6...10
Input current low [mA]	0...2
Switching level high [V]	> 11
Digital inputs protected against short circuits	yes
Operating conditions	
Ambient temperature [°C]	-25...70
Protection	IP 67

AC5215



AS-Interface ClassicLine module with quick mounting technology

ClassicLine 4DI-Y IP67

Tests / approvals					
EMC	EN 50295				
	IEC 61000-6-2				
MTTF	[years]	405			
AS-i classification					
AS-i version	2.11; 3.0				
AS-i addressing	Addressing socket				
Extended addressing mode	yes				
AS-i master profile	M2; M3; M4				
AS-i profile	S-0.A.E				
AS-i I/O configuration	[hex]	0			
AS-i ID code	[hex]	A.E			
Data bits	Data bit	D0	D1	D2	D3
	Input	1	2	3	4
	Socket	I-1/2	I-1/2 I-2	I-3/4	I-3/4 I-4
	Pin	4	2 4	4	2 4
Mechanical data					
Weight	[g]	155.6			
Housing	rectangular				
Type of mounting	AS-i flat cable connection; Mounting on DIN rail; (TH35 (EN 60715))				
Dimensions	[mm]	103 x 45 x 44.7			
Material	PA; Piercing contacts: CuSn6 nickel-plated and tin-plated				
Displays / operating elements					
Display	Power	LED, green			
	errors	LED, red			
	Function	LED, yellow			
Electrical connection					
Module connection	Flat cable				
Accessories					
Items supplied	lower part				
Accessories (optional)	Protective cap: M12, E73004				
Remarks					
Remarks	Do not connect any of the following points to an external potential:				
	I-, I+, I-1/2, I-2, I-3/4, I-4				
	The connections are electrically connected with the AS-i cable.				
Pack quantity	cULus - Class 2 source required				
	1 pcs.				

AC5215



AS-Interface ClassicLine module with quick mounting technology

ClassicLine 4DI-Y IP67

Electrical connection

quick mounting technology for AS-i flat cable: ; three selectable directions

Connection

AN_i_1360_GG

Original Scale Drawing (MTD)

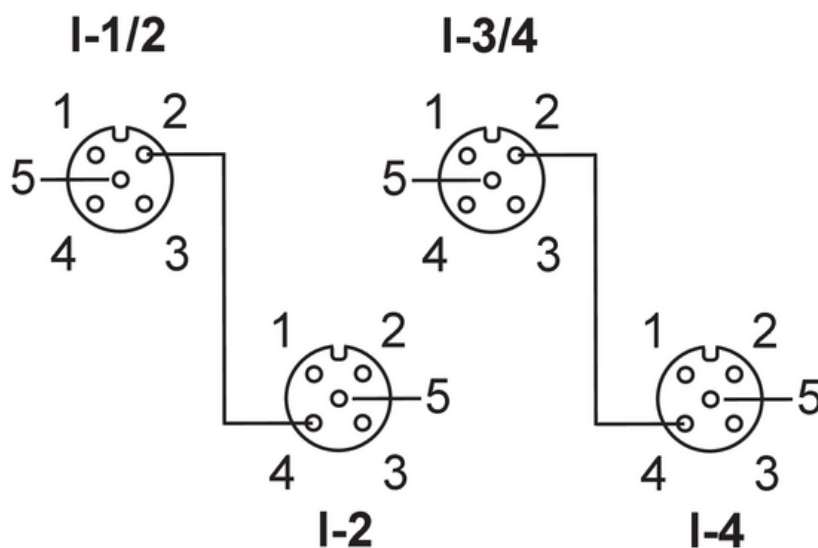

EPS Source
Product Scale Drawing
Frame Size: 75 mm x 45 mm

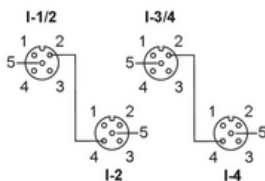

AC5215



AS-Interface ClassicLine module with quick mounting technology

ClassicLine 4DI-Y IP67

Connector: M12

	Inputs
	Socket I-1/2
1	Sensor supply L+
2	Data input 2
3	Sensor supply L-
4	Data input 1
5	not used
	Socket I-2
1	Sensor supply L+
2	not used
3	Sensor supply L-
4	Data input 2
5	not used
	Socket I-3/4
1	voltage supply L+
2	Data input 4
3	Sensor supply L-
4	Data input 3
5	not used
	Socket I-4
1	Sensor supply L+
2	not used
3	Sensor supply L-
4	Data input 4
5	not used