

SM6000

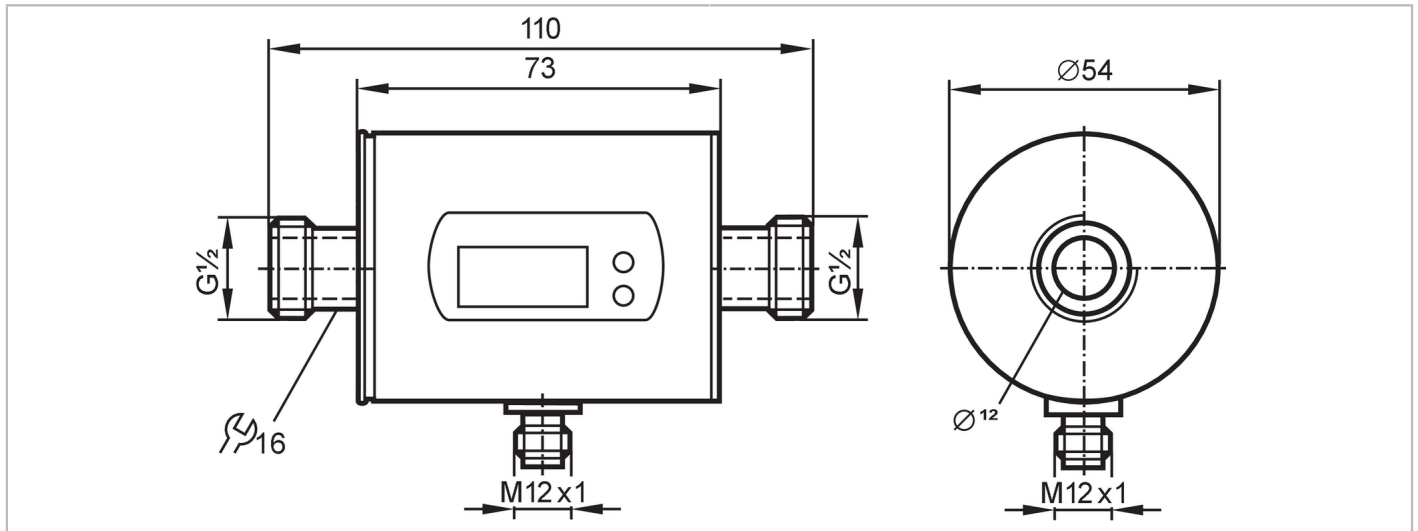

Magnetic-inductive flow meter

SMR12GGXFRKG/US-100



Product characteristics

Number of inputs and outputs	Number of digital outputs: 2; Number of analog outputs: 1	
Measuring range	0.1...25 l/min	0.005...1.5 m ³ /h
Process connection	threaded connection G 1/2 external thread DN15 flat seal	

Application

Special feature	gold-plated contacts	
Application	Totalizer function; for industrial applications	
Installation	connection to pipe by means of an adapter	
Media	Conductive liquids; water; water-based media	
Note on media	conductivity: $\geq 20 \mu\text{S}/\text{cm}$ viscosity: $< 70 \text{ mm}^2/\text{s}$ (40 °C)	
Medium temperature [°C]	-10...70	
Pressure rating	16 bar	1.6 MPa
MAWP (for applications according to CRN)	15.3 bar	1.53 MPa

Electrical data

Operating voltage [V]	18...30 DC; (to SELV/PELV)	
Current consumption [mA]	95; (24 V)	
Min. insulation resistance [MΩ]	100; (500 V DC)	
Protection class	III	
Reverse polarity protection	yes	
Power-on delay time [s]	5	
Measuring principle	magnetic-inductive	

Inputs / outputs

Number of inputs and outputs	Number of digital outputs: 2; Number of analog outputs: 1	
------------------------------	---	--

Inputs

Inputs	counter reset	
--------	---------------	--

Outputs

Total number of outputs	2	
-------------------------	---	--

SM6000



Magnetic-inductive flow meter

SMR12GGXFRKG/US-100

Output signal	switching signal; analog signal; pulse signal; IO-Link; (configurable)	
Electrical design	PNP/NPN	
Number of digital outputs	2	
Output function	normally open / closed; (configurable)	
Max. voltage drop switching output DC [V]	2	
Permanent current rating of switching output DC [mA]	200	
Number of analog outputs	1	
Analog current output [mA]	4...20; (scalable)	
Max. load [Ω]	500	
Analog voltage output [V]	0...10; (scalable)	
Min. load resistance [Ω]	2000	
Pulse output	flow rate meter	
Short-circuit protection	yes	
Type of short-circuit protection	yes (non-latching)	
Overload protection	yes	

Measuring/setting range

Measuring range	0.1...25 l/min	0.005...1.5 m³/h
Display range	-30...30 l/min	-1.8...1.8 m³/h
Resolution	0.02 l/min	0.002 m³/h
Set point SP	0.25...25 l/min	0.015...1.5 m³/h
Reset point rP	0.1...24.9 l/min	0.005...1.495 m³/h
Analog start point ASP	0...20 l/min	0...1.2 m³/h
Analog end point AEP	5...25 l/min	0.3...1.5 m³/h
In steps of	0.02 l/min	0.002 m³/h

Volumetric flow quantity monitoring

Pulse value	0.00001...30 000 m³	
Pulse length [s]	0,01...2	

Temperature monitoring

Measuring range [°C]	-20...80	
Resolution [°C]	0.2	
Set point SP [°C]	-19.2...80	
Reset point rP [°C]	-19.6...79.6	
Analog start point [°C]	-20...60	
Analog end point [°C]	0...80	
In steps of [°C]	0.2	

Accuracy / deviations

Flow monitoring

Accuracy (in the measuring range)	± (0,8 % MW + 0,5 % MEW)	
Repeatability	± 0,2% MEW	

Temperature monitoring

Accuracy [K]	± 2,5 (Q > 1 l/min)	
--------------	---------------------	--

SM6000



Magnetic-inductive flow meter

SMR12GGXFRKG/US-100

Reaction times		
Flow monitoring		
Response time	[s]	0.15; (dAP = 0, T19)
Delay time programmable dS, dr	[s]	0...50
Damping process value dAP	[s]	0...5
Temperature monitoring		
Dynamic response T05 / T09	[s]	T09 = 20 (Q > 1 l/min)
Software / programming		
Parameter setting options	Flow monitoring; quantity meter; Preset counter; Temperature monitoring; hysteresis / window; normally open / closed; switching logic; current/voltage/pulse output; Start-up delay; display can be deactivated; Display unit	
Interfaces		
Communication interface	IO-Link	
Transmission type	COM2 (38,4 kBaud)	
IO-Link revision	1.1	
SDCI standard	IEC 61131-9	
Profiles	Smart Sensor - SSP 0	Generic Profiled Sensor
	Function	Device identification
	Function	Process data variable
	Function	Device diagnosis
SIO mode	yes	
Required master port class	A	
Process data analog	3	
Process data binary	2	
Min. process cycle time	[ms]	5
Supported DeviceIDs	Type of operation	DeviceID
	default	569
Operating conditions		
Ambient temperature	[°C]	-10...60
Storage temperature	[°C]	-25...80
Protection	IP 67	
Tests / approvals		
EMC	DIN EN 60947-5-9	
CPA approval	model number	001MI
	accuracy class	-
	maximum allowable error	± 1,5 % FS
	Q (min)	0,005 m³/h
	Q (t)	-
	Q (max)	1,5 m³/h
Shock resistance	DIN IEC 68-2-27	20 g (11 ms)
Vibration resistance	DIN IEC 68-2-6	5 g (10...2000 Hz)
MTTF	[years]	162
Pressure equipment directive	sound engineering practice; can be used for group 2 fluids; group 1 fluids on request	

SM6000



Magnetic-inductive flow meter

SMR12GGXFRKG/US-100

Mechanical data	
Weight [g]	544
Housing	tubular
Inlet pipe length	3 x DN
Outlet pipe length	1 x DN
Dimensions [mm]	Ø 54 / L = 110
Material	stainless steel (1.4404 / 316L); PBT-GF20; PC; FKM; TPE
Materials (wetted parts)	stainless steel (1.4404 / 316L); PEEK; FKM
Process connection	threaded connection G 1/2 external thread DN15 flat seal

Displays / operating elements		
Display	Display unit	6 x LED, green (l/min, m ³ /h, l, m ³ , 10 ³ , °C)
	Switching status	2 x LED, yellow
	Measured values	alphanumeric display, 4-digit
	Programming	alphanumeric display, 4-digit

Remarks	
Remarks	MW = Measured value MEW = Final value of the measuring range
Pack quantity	1 pcs.

Electrical connection

Connector: 1 x M12; coding: A; Contacts: 4, gold-plated



SM6000



Magnetic-inductive flow meter

SMR12GGXFRKG/US-100

Connection

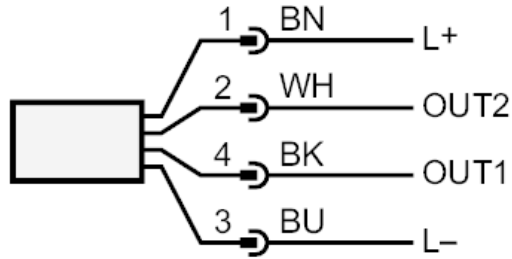

Colors to DIN EN 60947-5-2

OUT1:

- Switching output Volumetric flow quantity monitoring
- Pulse output quantity meter
- signal output Preset counter
- IO-Link

OUT2:

- Switching output Volumetric flow quantity monitoring
- Switching output Temperature monitoring
- analog output Volumetric flow quantity monitoring
- analog output Temperature monitoring
- Input counter reset

Core colors :

- BK = black
- BN = brown
- BU = blue
- WH = white

Diagrams and graphs

Pressure loss

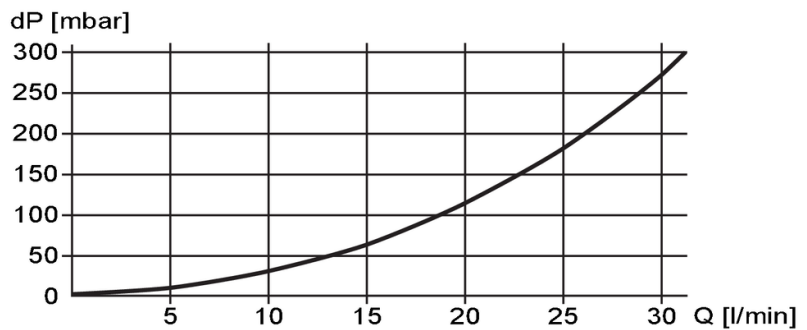

dP Pressure loss

Q volumetric flow quantity