

LR8000



Continuous level sensor (guided wave radar)

LR0000B-BR34ASPKG/US

For high process temperatures: The temperature at the process connection is decisive. The actual medium temperature may be higher.

For 8-wire cordsets the core colors are not standardized.
Please note the wiring of the sensor and the cordsets (see data sheet).
Please see the technical note under "Downloads"

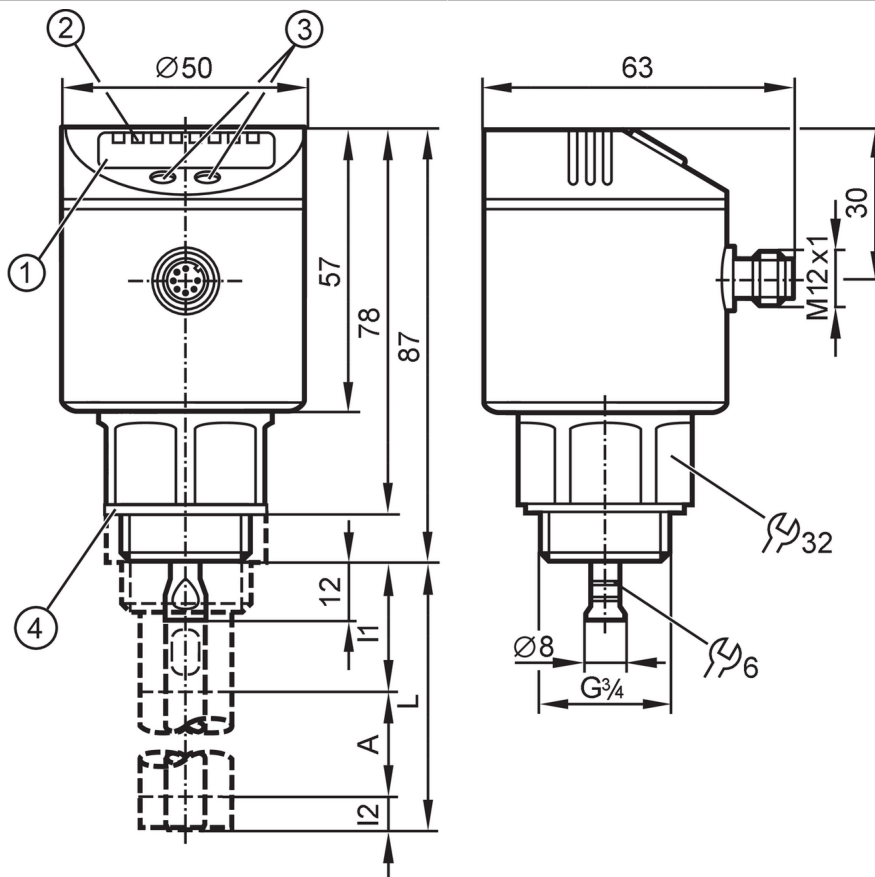

- 1 alphanumeric display 4-digit
- 2 LEDs Display unit / Switching status
- 3 Programming buttons
- 4 sealing
- A Active zone
- I1 / I2 Inactive ranges



Product characteristics	
Number of inputs and outputs	Number of digital outputs: 4
Probe length L [mm]	100...1600
Process connection	threaded connection G 3/4 external thread
Application	
Special feature	gold-plated contacts
Application	for industrial applications
Media	Liquids
Dielectric constant of the medium	$\geq 1,8$; (for media with a dielectric constant of 1.8...5 (e.g. oils), a coaxial pipe is needed for operation)

LR8000



Continuous level sensor (guided wave radar)

LR0000B-BR34ASPKG/JS

Recommended media	water; water-based media; oils; oil-based media	
Cannot be used for	See the operating instructions, chapter "Function and features".	
Process temperature [°C]	-25...80; (90 < 1 h ; see note under remarks)	
Pressure rating	16 bar	1.6 MPa
Vacuum resistance	-1000 mbar	-0.1 MPa
MAWP (for applications according to CRN) [bar]	16	
Electrical data		
Operating voltage [V]	18...30 DC	
Current consumption [mA]	< 30	
Protection class	III	
Reverse polarity protection	yes	
Power-on delay time [s]	< 3	
Measuring principle	guided wave radar	
Inputs / outputs		
Number of inputs and outputs	Number of digital outputs: 4	
Outputs		
Total number of outputs	4	
Output signal	switching signal; IO-Link	
Electrical design	PNP	
Number of digital outputs	4	
Output function	normally open / closed; (configurable)	
Max. voltage drop switching output DC [V]	2.5	
Permanent current rating of switching output DC [mA]	200	
Short-circuit protection	yes	
Type of short-circuit protection	thermal, pulsed	
Overload protection	yes	
Measuring/setting range		
Probe length L [mm]	100...1600	
Active range A [mm]	L-40; (when set to oil and oil based media: L-60)	
Inactive range I1 / I2 [mm]	30 / 10; (when set to oil and oil based media: 30 / 30)	
Sampling rate [Hz]	4	
Setting range		
Set point SP [mm]	15...L-30	
Note on setpoint SP	when set to oil and oil based media: 35...L-30	
Reset point rP [mm]	10... L-35	
Note on reset point rP	when set to oil and oil based media: 30...L-35	
In steps of [mm]	5	
Hysteresis [mm]	> 5	
Accuracy / deviations		
Repeatability [mm]	± 5	
Measuring error [mm]	± 7	

LR8000



Continuous level sensor (guided wave radar)

LR0000B-BR34ASPKG/US

Offset error	[mm]	5
Resolution	[mm]	1
Temperature drift per 10 K		± 0.2 %

Interfaces

Communication interface	IO-Link	
Transmission type	COM2 (38,4 kBaud)	
IO-Link revision	1.1	
SDCI standard	IEC 61131-9 CDV	
SIO mode	yes	
Required master port class	A	
Process data analog	1	
Process data binary	4	
Min. process cycle time	[ms]	2.3
Supported DeviceIDs	Type of operation	DeviceID
	default	10

Operating conditions

Ambient temperature	[°C]	-25...60
Storage temperature	[°C]	-40...85
Protection		IP 67

Tests / approvals

EMC	DIN EN 61000-6-2	
	DIN EN 61000-6-3	in a closed metal tank
	DIN EN 61000-6-4	in plastic or open metal tanks
Shock resistance	DIN EN 60068-2-27	50 g (11 ms) / 25 g (6 ms) with reference rod 0.5 m
Vibration resistance	DIN EN 60068-2-6	5 g (10...2000 Hz) / 1 g (5...200 Hz) with reference rod 0.5 m
MTTF	[years]	205
UL approval	UL approval number	H008
	File number UL	E174191

Mechanical data

Weight	[g]	380.45
Dimensions	[mm]	Ø 50 / L = 99
Material	stainless steel (1.4301 / 304); stainless steel (1.4404 / 316L); FKM; PBT; PC; PEI; TPE-V	
Materials (wetted parts)	stainless steel (1.4305 / 303); probe connection: stainless steel (1.4435 / 316L); PTFE; FKM; sealing: NBR fiber-reinforced	
Process connection	threaded connection G 3/4 external thread	

Displays / operating elements

Display	Display unit	3 x LED, green
	Switching status	4 x LED, yellow
	Level	alphanumeric display, 4-digit
	Parameter setting	alphanumeric display, 4-digit

Remarks

Notes	For high process temperatures: The temperature at the process connection is decisive. The actual medium temperature may be higher.
Pack quantity	1 pcs.

LR8000



Continuous level sensor (guided wave radar)

LR0000B-BR34ASPKG/US

Electrical connection

Connector: 1 x M12; coding: A; Contacts: 7, gold-plated

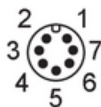

Connection

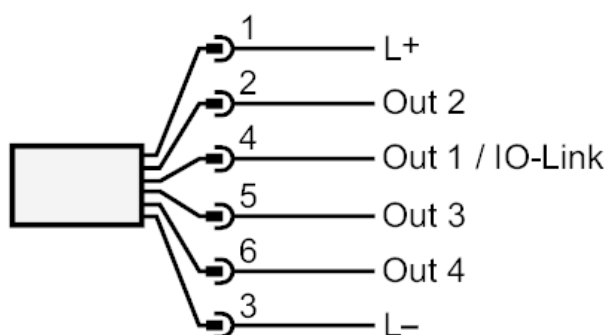

Diagrams and graphs

Measurement deviation D at the limits of the active rod range

