

OGP280

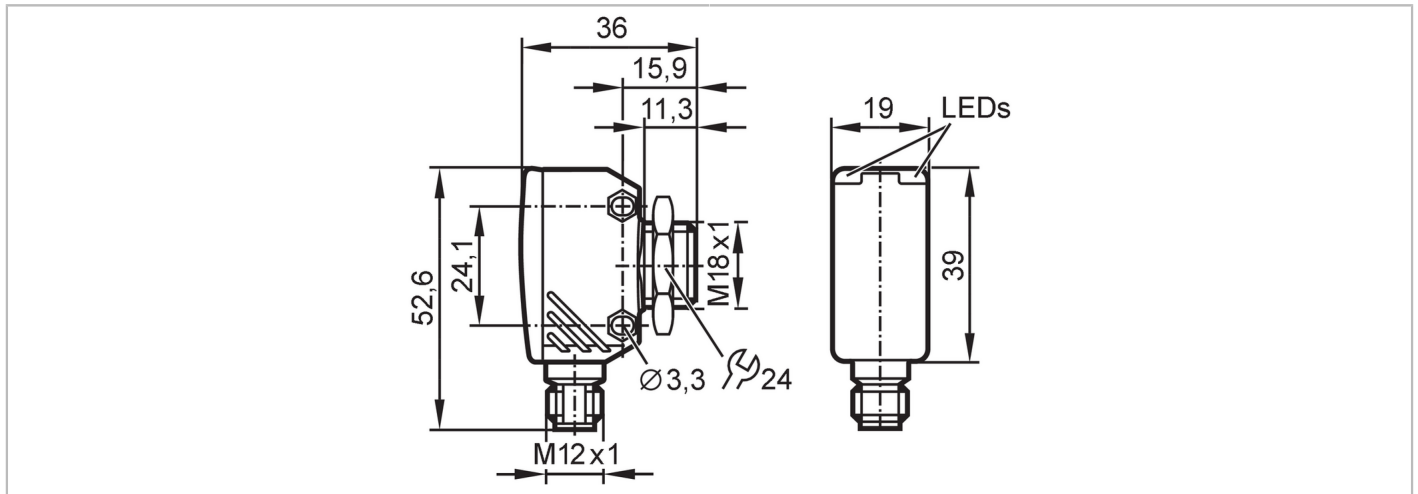

Retro-reflective sensor

OGP-DPKG/US/CUBE



Product characteristics	
Type of light	red light
Housing	rectangular with M18 thread
Application	
Special feature	polarization filter
Function principle	Retro-reflective sensor
Application	Industrial applications
Electrical data	
Operating voltage [V]	10...30 DC; (cULus - Class 2 source required)
Rated insulation voltage [V]	32
Current consumption [mA]	21
Protection class	III
Reverse polarity protection	yes
Max. power-on delay time [ms]	300
Type of light	red light
Wave length [nm]	662
Outputs	
Electrical design	PNP
Output function	dark-on mode
Max. voltage drop switching output DC [V]	2.5
Permanent current rating of switching output DC [mA]	200
Switching frequency DC [Hz]	1000
Short-circuit protection	yes
Type of short-circuit protection	yes (non-latching)
Monitoring range	
Range referred to prismatic reflector [m]	0.1...4; (Prismatic reflector Ø 80 E20005)

OGP280



Retro-reflective sensor

OGP-DPKG/US/CUBE

Max. light spot diameter [mm]	160
Light spot dimensions refer to	at maximum range
Polarization filter available	yes

Interfaces

Communication interface	IO-Link	
Transmission type	COM2 (38,4 kBaud)	
IO-Link revision	1.1	
SDCI standard	IEC 61131-9	
Profiles	Smart Sensor - SSP 0	Generic Profiled Sensor
	Common - I&D	Identification and Diagnosis
	Function	Multiple switching signal
	Function	Teach channel
SIO mode	yes	
Required master port class	A	
Min. process cycle time [ms]	2.5	
IO-Link process data (cyclical)	Function	bit length
	device status	4
IO-Link functions (acyclical)	binary switching information	1
	application specific tag; operating hours counter; switching cycles counter	
Supported DeviceIDs	Type of operation	DeviceID
	default	1134
Note	For further information please see the IODD PDF file at "Downloads"	

Operating conditions

Ambient temperature [°C]	-25...60
Storage temperature [°C]	-40...60
Protection	IP 65; IP 67

Tests / approvals

EMC	EN 60947-5-2	
MTTF [years]	905	
UL approval	Ta	-25...60 °C
	Enclosure type	Type 1
	voltage supply	Class 2
	File number UL	E174191

Mechanical data

Weight [g]	58.5	
Housing	rectangular with M18 thread	
Dimensions [mm]	52.6 x 19 x 36	
Thread designation	M18 x 1	
Material	housing: diecast zinc; rear of the housing: PEI	
Lens material	front lens:PMMA	
Lens alignment	Side sensing	

Displays / operating elements

Display	Switching status	1 x LED, yellow
	Power	1 x LED, green

OGP280



Retro-reflective sensor

OGP-DPKG/US/CUBE

Accessories	
Items supplied	lock nut: 1
Remarks	
Remarks	cULus - Class 2 source required
Pack quantity	1 pcs.

Electrical connection

Connector: 1 x M12; coding: A; Contacts: 4



Connection

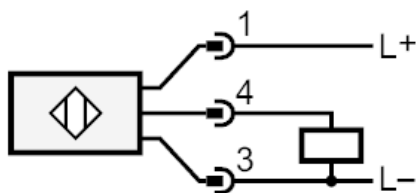

Diagrams and graphs

excess gain graph

