

O5H500

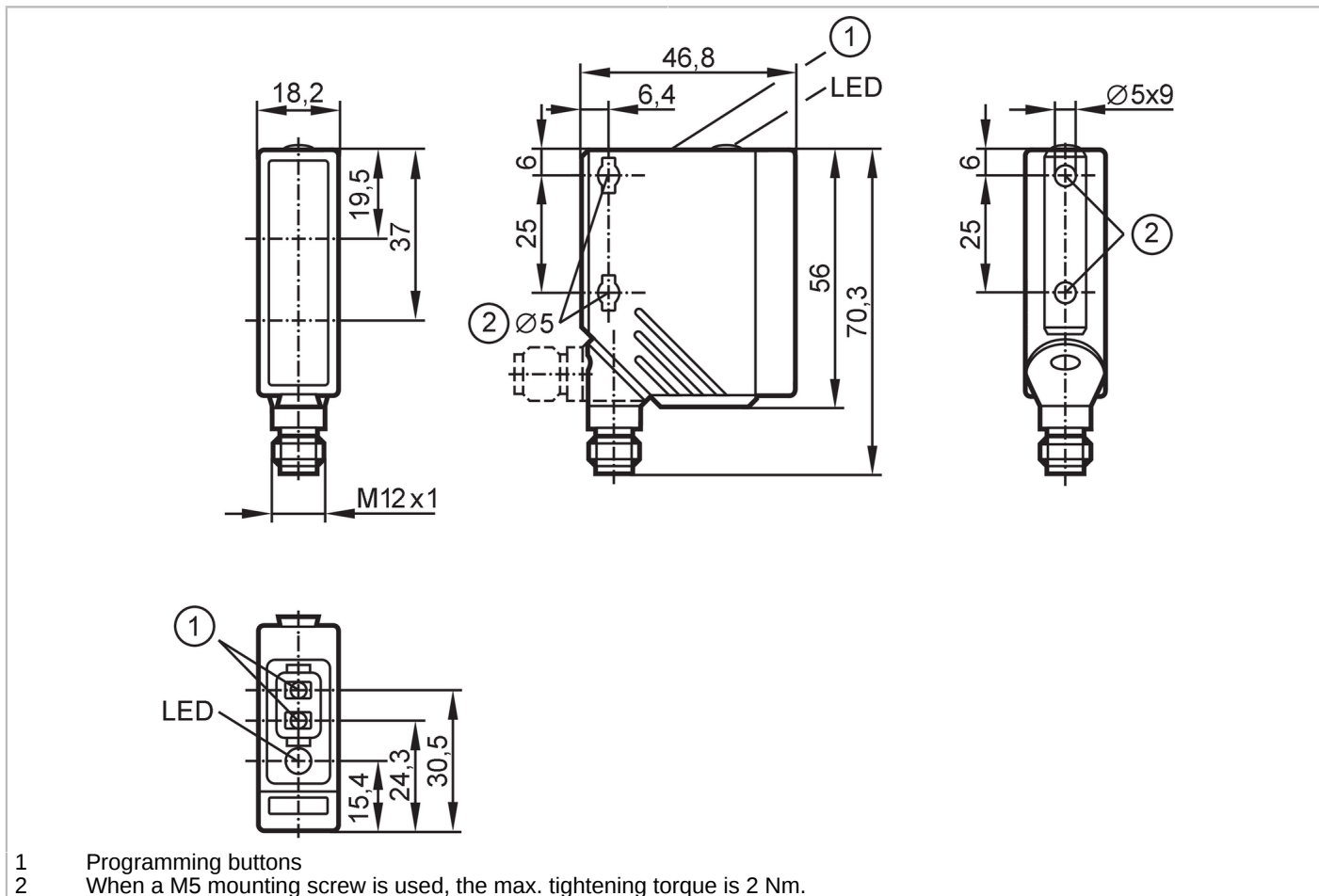

Diffuse reflection sensors with background suppression

O5H-FPKG/US100



Product characteristics	
Type of light	red light
Housing	rectangular
Application	
Special feature	Background suppression
Function principle	Diffuse reflection sensor
Application	Industrial applications
Electrical data	
Operating voltage [V]	10...36 DC
Current consumption [mA]	25
Protection class	II
Reverse polarity protection	yes
Type of light	red light
Wave length [nm]	624
Outputs	
Electrical design	PNP
Output function	light-on/dark-on mode; (programmable)

O5H500



Diffuse reflection sensors with background suppression

O5H-FPKG/US100

Max. voltage drop switching output DC [V]	2.5
Permanent current rating of switching output DC [mA]	200
Switching frequency DC [Hz]	1000
Short-circuit protection	yes
Type of short-circuit protection	yes (non-latching)
Overload protection	yes

Monitoring range

Range [mm]	50...1800; (white paper 200 x 200 mm 90 % remission)
Range on white object (90 % remission) [mm]	50...1800
Range on grey object (18 % remission) [mm]	50...900
Range on black object (6 % remission) [mm]	50...600
Range adjustable	yes
Max. light spot diameter [mm]	50
Light spot dimensions refer to	Range
Background suppression available	yes

Operating conditions

Ambient temperature [°C]	-25...60
Protection	IP 67

Tests / approvals

EMC	EN 60947-5-2
MTTF [years]	360

Mechanical data

Weight [g]	67.5
Housing	rectangular
Dimensions [mm]	56 x 18.2 x 46.8
Material	housing: PA; Front framework: stainless steel; operator interface: TPU (urethane)
Lens material	front lens:PMMA
Lens alignment	Side sensing

Displays / operating elements

Display	Switching status	1 x LED, yellow
Teach function		yes
Electronic lock		yes

Remarks

Remarks	cULus - Class 2 source required
Pack quantity	1 pcs.

O5H500



Diffuse reflection sensors with background suppression

O5H-FPKG/US100

Electrical connection

Connector: 1 x M12; coding: A; Contacts: 4



Connection

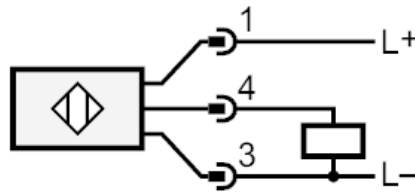

Diagrams and graphs

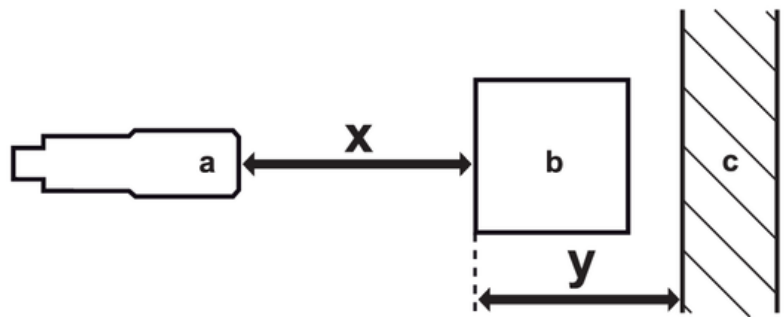

- a: sensor
- b: object
- c: background
- x: distance sensor/object [mm]
- y: min. distance object/background [mm]



Diffuse reflection sensors with background suppression

O5H-FPKG/US100

Background suppression chart

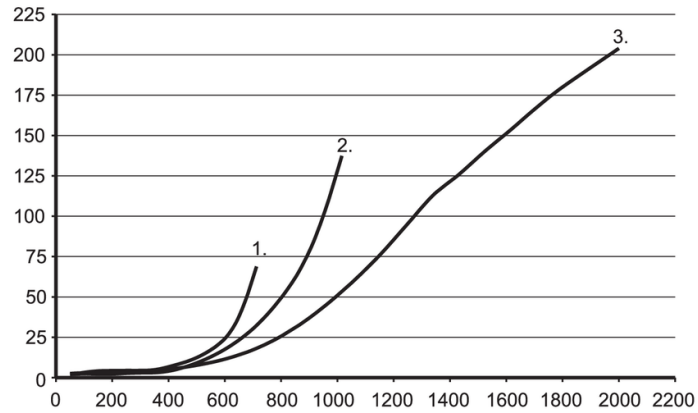

x: distance sensor/object [mm]

y: min. distance object/background [mm]

1 = object black (6 % remission) , Background white (90 % remission)

2 = object grey (18 % remission) , Background white (90 % remission)

3 = object white (90 % remission) , Background white (90 % remission)