

AC5225

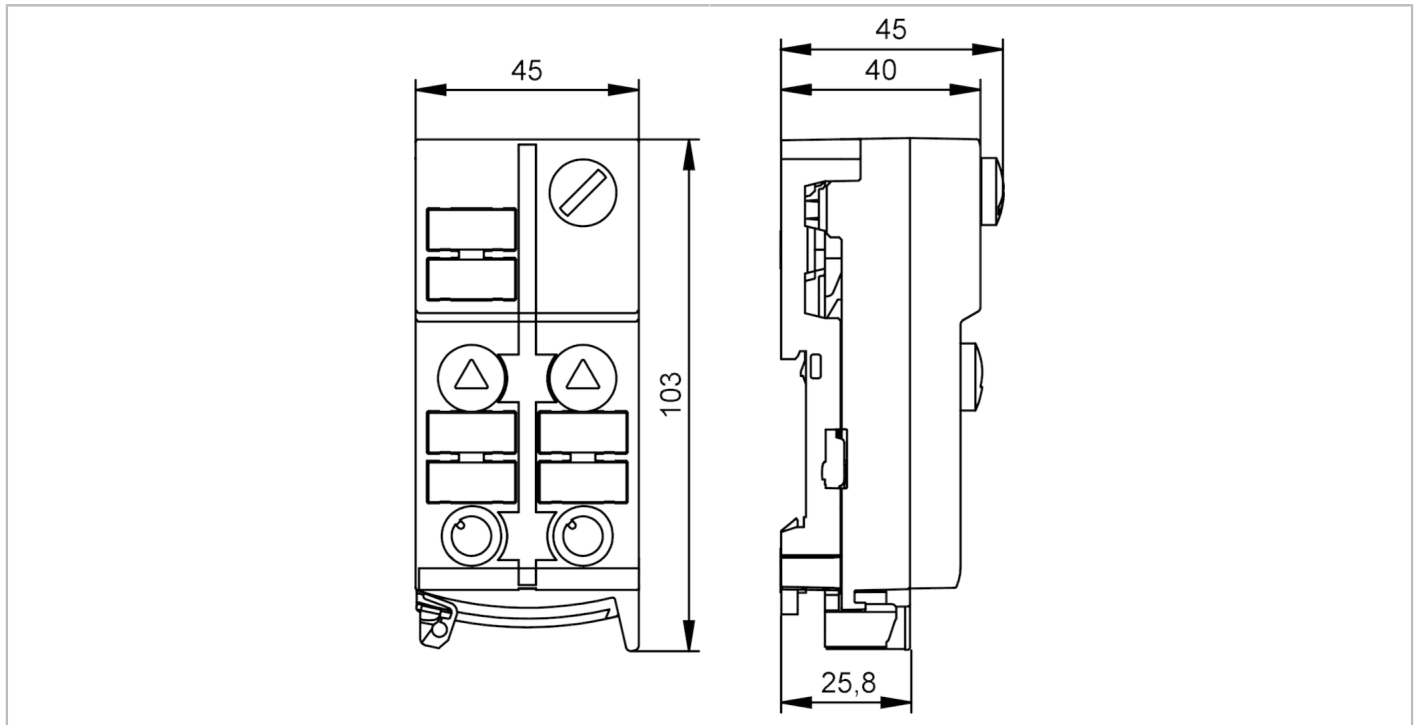

AS-Interface ClassicLine module with quick mounting technology

ClassicLine IO-Link 2 Ports



Application	
Design	housing for DIN rail mounting, Only for operation with AS-i masters with the profile M4
Application	field installation
Electrical data	
Operating voltage [V]	26.5...31.6 DC
Max. current consumption from AS-i [mA]	300
Reverse polarity protection	yes
Additional voltage supply [V]	20...30 DC
Inputs	
Sensor supply of the inputs	AS-i
Digital inputs protected against short circuits	yes
Interfaces	
Communication interface	IO-Link; AS-i
IO-Link Device	
Min. process cycle time [ms]	2.3
IO-Link Master	
Transmission type	COM1 (4,8 kBaud); COM2 (38,4 kBaud)
IO-Link revision	1.0
Number of ports class A	2
Operating conditions	
Ambient temperature [°C]	-25...70
Protection	IP 67



AS-Interface ClassicLine module with quick mounting technology

ClassicLine IO-Link 2 Ports

Tests / approvals		
EMC	EN 50295	
MTTF [years]		149
AS-i classification		
AS-i version		3.0
AS-i addressing		Addressing socket
Extended addressing mode		no
AS-i master profile		M4
AS-i profile		S-7.5.5
AS-i I/O configuration [hex]		7
AS-i ID code [hex]		5.5
Mechanical data		
Weight [g]		161.35
Housing		rectangular
Type of mounting		quick mounting; AS-i flat cable connection; Mounting on DIN rail; (TH35 (EN 60715))
Dimensions [mm]		103 x 45 x 44.7
Material		PA; Piercing contacts: CuSn6 nickel-plated and tin-plated
Displays / operating elements		
Display	Power	PWR LED, green Voltage AS-i
	errors	LED, red
	Switching status	LED, yellow DI/DO Port 1, Port 2
	communication	LED, green IO-Link Port 1, Port 2
	disturbed communication	LED, red Port 1, Port 2
Electrical connection		
Module connection		Flat cable
Accessories		
Items supplied		lower part
Accessories (optional)		Protective cap: M12, E73004
Remarks		
Remarks		When the sensors and actuators are supplied from AS-i the load must not exceed a maximum of 200 mA.
		There is an electrical connection between the sensor and AS-i.
		cULus - Class 2 source required
Pack quantity		1 pcs.
Electrical connection		
quick mounting technology for AS-i flat cable: ; three selectable directions		
Connector: M12; coding: A; Contacts: 3		
1	Sensor supply +24V (L+ in IO-Link)	
2	n.c.	
3	Sensor supply 0V (L- in IO-Link)	
4	DI / DO for IO-Link communication	
5	n.c.	