

SA2000

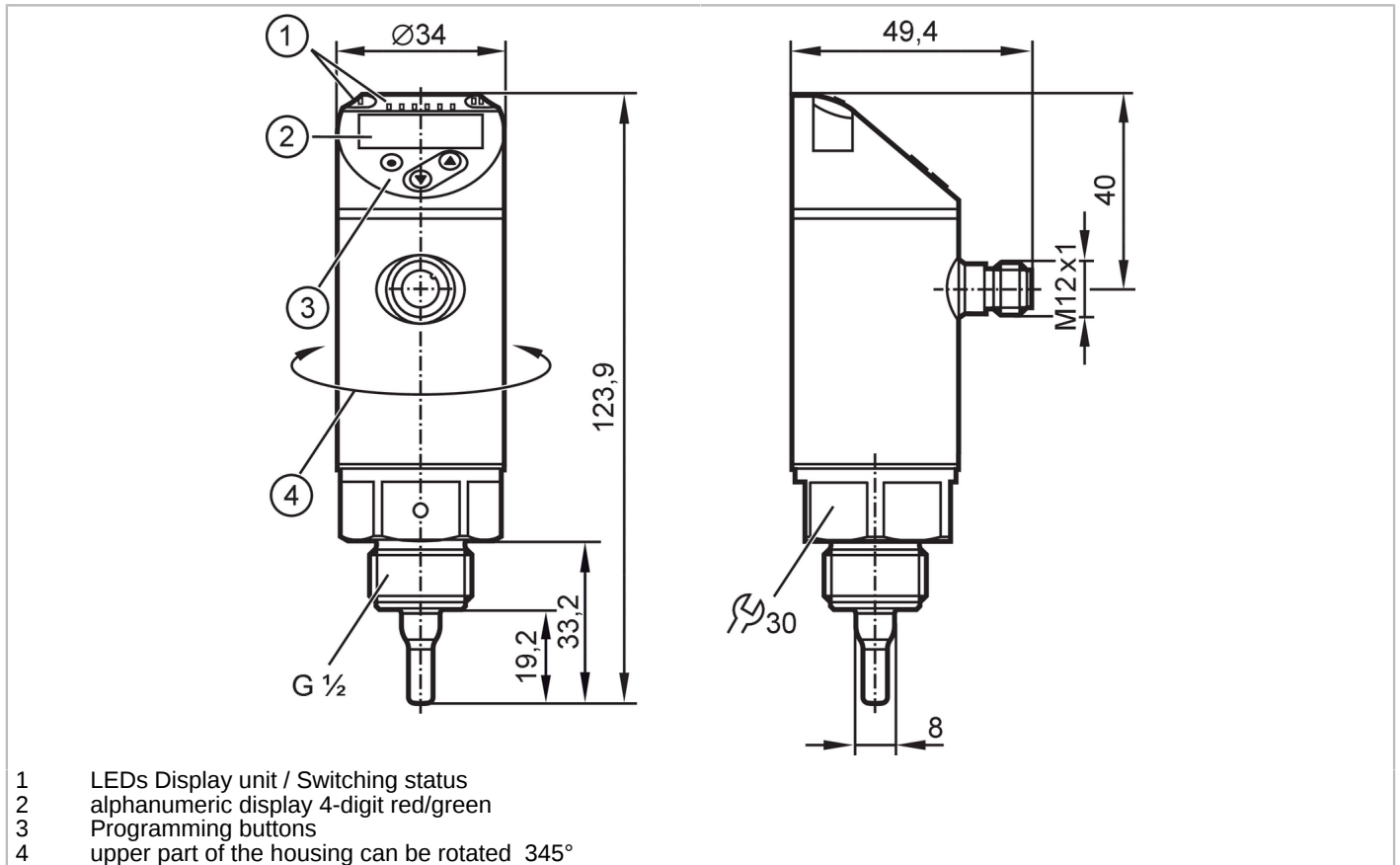

Flow sensor

SAR12XDBFRKG/US-100



- 1 LEDs Display unit / Switching status
- 2 alphanumeric display 4-digit red/green
- 3 Programming buttons
- 4 upper part of the housing can be rotated 345°



Product characteristics

Number of inputs and outputs	Number of digital outputs: 2; Number of analog outputs: 1
Process connection	threaded connection G 1/2 external thread

Application

Special feature	gold-plated contacts
Media	water; glycol solutions; air; oils
Note on media	low-viscosity oils with viscosity: $\leq 40 \text{ mm}^2/\text{s}$ (40 °C) high-viscosity oils with viscosity: $> 40 \text{ mm}^2/\text{s}$ (40 °C)
Medium temperature [°C]	-20...90
Pressure rating	100 bar 10 MPa
MAWP (for applications according to CRN) [bar]	85

Electrical data

Operating voltage [V]	18...30 DC
Current consumption [mA]	< 100
Protection class	III
Reverse polarity protection	yes
Power-on delay time [s]	10
Measuring principle	calorimetric

Inputs / outputs

Number of inputs and outputs	Number of digital outputs: 2; Number of analog outputs: 1
------------------------------	---

SA2000



Flow sensor

SAR12XDBFRKG/US-100

Outputs	
Total number of outputs	2
Output signal	switching signal; analog signal; frequency signal; IO-Link; (configurable)
Electrical design	PNP/NPN
Number of digital outputs	2
Output function	normally open / closed; (configurable)
Max. voltage drop switching output DC [V]	2.5
Permanent current rating of switching output DC [mA]	250
Number of analog outputs	1
Analog current output [mA]	4...20; (scalable)
Max. load [Ω]	350
Short-circuit protection	yes
Type of short-circuit protection	yes (non-latching)
Overload protection	yes
Frequency of the output [Hz]	0...1000
Measuring/setting range	
Probe length L [mm]	19.2
Operating mode	relative; absolutely liquid; absolutely gaseous; (absolute: reference measurement recommended; Factory setting: relative)
Temperature monitoring	
Measuring range [°C]	-20...90
Resolution [°C]	0.2
Liquid media - absolute operating mode	
Setting range [m/s]	0.04...3
Greatest sensitivity [m/s]	0.04...3
Liquid media - relative operating mode	
Setting range [m/s]	0.04...6
Greatest sensitivity [m/s]	0.04...3
Gases - operating mode "absolute"	
Setting range [m/s]	2...100
Greatest sensitivity [m/s]	30...100
Gases - operating mode "relative"	
Setting range [m/s]	2...200
Greatest sensitivity [m/s]	30...100
Accuracy / deviations	
Temperature drift [cm/s x 1/K]	0,003 m/s x 1/K (< 20 °C; > 70 °C)
Max. temperature gradient of [K/min] medium	100
Absolute operating mode	
Repeatability	0,05 m/s; (water; Flow velocity: 0,05...3 m/s)

SA2000



Flow sensor

SAR12XDBFRKG/US-100

Relative operating mode		
Accuracy	$\pm (7 \% MW + 2 \% MEW)$; (for relative mode in the range of maximum sensitivity under the following conditions:; water: 20...70 °C; inlet length: 1.5 m; DN25 (DIN 2448); mounting position according to instructions; Accuracy can differ for other media and mounting positions.)	
Repeatability	0,05 m/s; (water; Flow velocity: 0,05...3 m/s)	
Temperature monitoring		
Temperature drift	$\pm 0,005 \text{ K/}^\circ\text{C}$	
Accuracy [K]	$\pm 0,3 / \pm 1$; (water; Flow velocity: 0,3...3 m/s / air; Flow velocity: > 10 m/s)	
Reaction times		
Response time [s]	0.5; (T09; water; glycol: 0,8 s; air: 7 s; oil: 1,8 s; each T09)	
Temperature monitoring		
Dynamic response T05 / T09 [s]	1,5 (T09); (water; Flow velocity: 0,3...3 m/s)	
Software / programming		
Parameter setting options	hysteresis / window; normally open / closed; switching logic; current/frequency output; medium selection; Damping; Teach function; display can be rotated and switched off; standard unit of measurement; process value color	
Interfaces		
Communication interface	IO-Link	
Transmission type	COM2 (38,4 kBaud)	
IO-Link revision	1.1	
SDCI standard	IEC 61131-9	
Profiles	Smart Sensor - SSP 0	Generic Profiled Sensor
	Function	Device identification
	Function	Process data variable
	Function	Device diagnosis
SIO mode	yes	
Required master port class	A	
Process data analog	2	
Process data binary	2	
Min. process cycle time [ms]	3	
Supported DeviceIDs	Type of operation	DeviceID
	Factory setting / ModE = (REL)	533
	ModE = (GAS)	547
	ModE = (LIQU)	540
Operating conditions		
Ambient temperature [°C]	-40...80	
Storage temperature [°C]	-40...100	
Protection	IP 65; IP 67	
Tests / approvals		
EMC	DIN EN 60947-5-9	
Shock resistance	DIN EN 60068-2-27	50 g (11 ms)
Vibration resistance	DIN EN 60068-2-6	20 g (10...2000 Hz)
MTTF [years]		143
UL approval	UL approval number	I003
	File number UL	E174189

SA2000



Flow sensor

SAR12XDBFRKG/US-100

Mechanical data	
Weight [g]	270
Housing	tubular
Dimensions [mm]	Ø 34 / L = 123.9
Material	stainless steel (1.4404 / 316L); stainless steel (1.4310 / 301); PBT-GF20; PBT-GF30
Materials (wetted parts)	stainless steel (1.4404 / 316L); Gasket: FKM
Process connection	threaded connection G 1/2 external thread
Probe diameter [mm]	5
Installation length EL [mm]	19.2

Displays / operating elements		
Display	Display unit	6 x LED, green (% , m/s, l/min, m ³ /h, °C, 10 ³)
	Switching status	2 x LED, yellow
	Measured values	alphanumeric display, red/green 4-digit

Remarks	
Remarks	MW = Measured value MEW = Final value of the measuring range
Pack quantity	1 pcs.

Electrical connection

Connector: 1 x M12; coding: A; Contacts: 4, gold-plated



SA2000



Flow sensor

SAR12XDBFRKG/US-100

Connection



Colors to DIN EN 60947-5-2

OUT1:

- Switching output Volumetric flow quantity monitoring
- Frequency output Volumetric flow quantity monitoring
- IO-Link

OUT2:

- Switching output Volumetric flow quantity monitoring
- Switching output Temperature monitoring
- analog output Volumetric flow quantity monitoring
- analog output Temperature monitoring
- Frequency output Volumetric flow quantity monitoring
- Frequency output Temperature monitoring
- Input External Teach

Core colors :

- BK = black
- BN = brown
- BU = blue
- WH = white