

IGT202

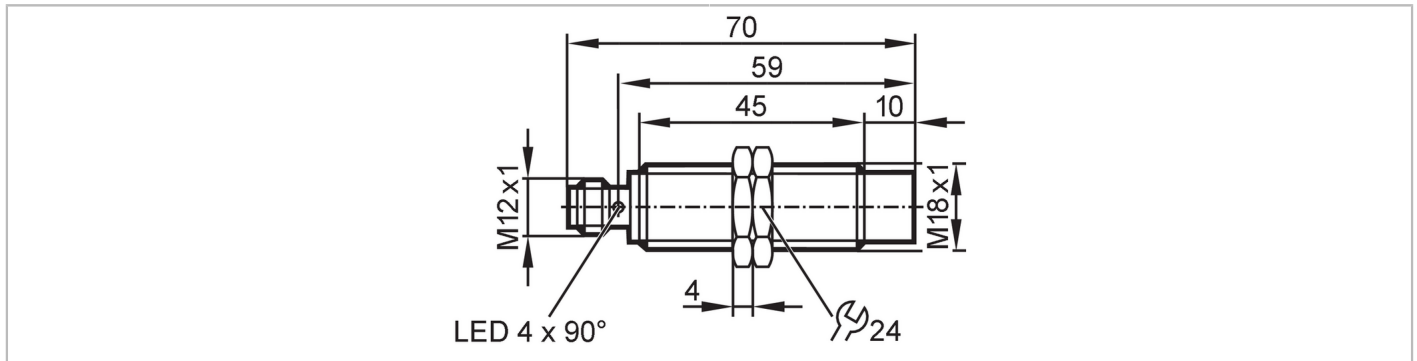

Inductive sensor

IGKC012-ASKG/2LED/V4A/US-104



Product characteristics	
Electrical design	PNP/NPN
Output function	normally open
Sensing range [mm]	12
Housing	Threaded type
Dimensions [mm]	M18 x 1 / L = 70
Application	
Special feature	gold-plated contacts; Increased sensing range; optical setting aid
Application	Use in hygienic areas / regular cleaning processes
Electrical data	
Operating voltage [V]	10...30 DC
Current consumption [mA]	< 15
Protection class	II
Reverse polarity protection	yes
Outputs	
Electrical design	PNP/NPN
Output function	normally open
Max. voltage drop switching output DC [V]	2.8
Minimum load current [mA]	2; (only in 2-wire operation)
Max. leakage current [mA]	0.6
Permanent current rating of switching output DC [mA]	100
Switching frequency DC [Hz]	300
Short-circuit protection	yes
Type of short-circuit protection	yes (non-latching)
Overload protection	yes
Monitoring range	
Sensing range [mm]	12
Real sensing range Sr [mm]	12 ± 10 %
Operating distance [mm]	0...9.72
Increased sensing range	yes

IGT202



Inductive sensor

IGKC012-ASKG/2LED/V4A/US-104

Accuracy / deviations		
Correction factor		steel: 1 / stainless steel: 0.7 / brass: 0.5 / aluminum: 0.4 / copper: 0.3
Hysteresis	[% of Sr]	1...20
Switch-point drift	[% of Sr]	-10...10
Operating conditions		
Ambient temperature	[°C]	0...100
Protection		IP 68; IP 69K
Tests / approvals		
EMC	EN 61000-4-2 ESD	4 kV CD / 8 kV AD
	EN 61000-4-3 HF radiated	10 V/m
	EN 61000-4-4 Burst	2 kV
	EN 61000-4-5 Surge	0,5 kV mains line to line
	EN 61000-4-6 HF conducted	10 V
	EN 55011	class B
MTTF	[years]	1359
UL approval	Ta	0...40 °C
	Enclosure type	Type 1
	voltage supply	Limited Voltage/Current
	UL approval number	A039
	File number UL	E174191
Mechanical data		
Weight	[g]	52.7
Housing		Threaded type
Mounting		non-flush mountable
Dimensions	[mm]	M18 x 1 / L = 70
Thread designation		M18 x 1
Material		housing: stainless steel (1.4404 / 316L); sensing face: PEEK natural; LED window: PEI; lock nuts: stainless steel (1.4404 / 316L)
Tightening torque	[Nm]	50
Displays / operating elements		
Display	Switching status	4 x 90° LED, yellow
	Setting aid	1 x LED, red
Optical setting aid		yes
Accessories		
Items supplied		lock nuts: 2
Remarks		
Remarks		suitable for PLC type 1 according to IEC 61131-2
Pack quantity		1 pcs.
Electrical connection - plug		
Connector: 1 x M12; coding: A; Contacts: 3, gold-plated		
		

IGT202



Inductive sensor

IGKC012-ASKG/2LED/V4A/US-104

Connection

