



Energy saving made easy

Precise compressed air measurement for effective energy management

- The basis for a comprehensive energy management system according to ISO 50001 or EMAS
- Improvement of energy efficiency via leakage monitoring
- Pressure monitoring thanks to the integrated pressure sensor
- Different process values being indicated simultaneously removes the need for multiple instruments



ifm – close to you!

“All-in-one sensor” reduces costs

The compressed air meter is a real all-rounder. Thanks to the integrated sensors for temperature and optionally also for pressure, the user can see four process values (flow rate, pressure, temperature and total consumption) at a glance, which provide information about the energy efficiency of their system. In addition to the inline versions, screw-in versions (SD1540, SD1440) are also available for pipes from 14 to 254 mm diameter and a pressure of up to 50 bar.

Energy efficiency thanks to leakage monitoring

The precise flow monitoring allows for leakage detection and energy cost savings. In addition, the high repeatability of the device enables exact allocation of the costs of compressed air to the respective production line as well as optimised product cost calculation.

Basis for seamless energy management

Following the EU directive on energy efficiency DIN EN ISO 50001, all member states have undertaken to achieve energy savings. The requirement for obtaining energy tax reductions is the implementation of an energy management system. Combining the compressed air meter with regular DAkkS calibrations provides the optimum basis for this.

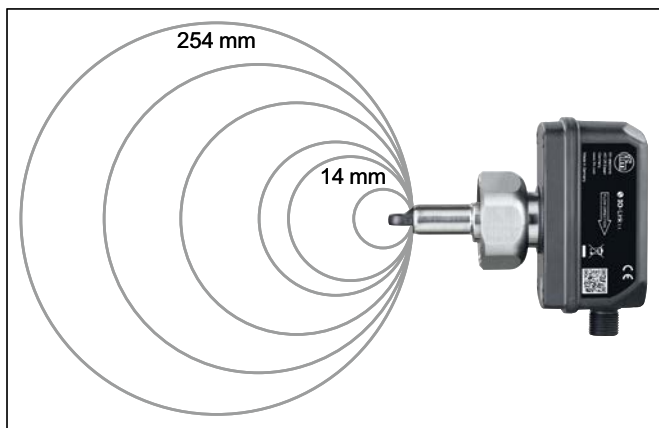

The sensor outputs the consumption depending on the pipe diameter.

Measuring range [m³/h]	Medium	Process connection	Order no.
0.05...15	air	G ¼ (DN8)	SD5500
0.25...75	air	R ½ (DN15)	SD6500
0.8...225	air	R 1 (DN25)	SD8500
1.4...410	air	R 1 ½ (DN40)	SD9500
2.5...700	air	R 2 (DN50)	SD2500
0.3...26260	air	G 1	SD1540
0.3...26260	air / nitrogen	G 1	SD1440

Calibration certificates	Order no.
ISO calibration (6 calibration points)	ZC0020
DAkkS calibration (6 calibration points)	ZC0075

Common technical data		
Flow		
Accuracy	[%]	± (2.0 MV + 0.5 MEW)
Repeatability	[%]	± (0.8 MV + 0.2 MEW)
Response time	[s]	0.1
Flow SD1440, SD1540		
Accuracy	[%]	± (6.0 MV + 0.6 MEW)
Repeatability	[%]	± (1.5 MV)
Response time	[s]	0.1
Temperature		
Measuring range	[°C]	-10...60
Pressure		
Measuring range	[bar]	-1...16
Output signal		Switching output, analogue output, pulse output, IO-Link (configurable)
Protection rating		IP67

MW = value of the measuring range
MEW = final value of the measuring range

BEST FRIENDS

We reserve the right to make technical alterations without prior notice. · 04.2024
ifm electronic gmbh · Friedrichstr. 1 · 45128 Essen



Pressure sensors
Especially for pneumatic processes



IO-Link masters
Field-compatible masters with Profinet interface



Compressed air meters
Precisely measures flow and consumption



For further technical details, please visit:
ifm.com/fs/SD5500