



Systems for condition monitoring
of machines

x, y and z axis: Sensor detects acceleration in three dimensions



Systems for vibration monitoring
and diagnostics



**Optimum condition analysis
thanks to acceleration
measurement in 3 axes**

**For connection to
VSE diagnostic electronics**

**Universal use thanks to
IEPE standard**

**Wide measuring range
for many different application
scenarios**

**Robust housings with
IP 67, IP 68 or IP 69K**



real-time

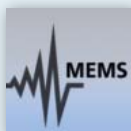

MEMS

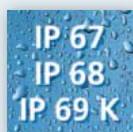

IP 67
IP 68
IP 69 K

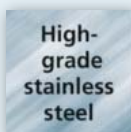

High-
grade
stainless
steel

For efficient vibration diagnostics

The VSM101 acceleration sensor can detect changes in vibration on the x, y and z axis. This spatial perception simplifies machine condition monitoring where forces and unbalances not only affect just one axis of motion, as is the case with motors and moving parts of the installation.

Important indicator of condition monitoring

The acceleration signal plays an important role in machine and plant condition monitoring. It is an indicator of various symptoms, such as unbalance, damaged bearings or crashes that may lead to machine failure or even irreparable damage.

The detected raw data is transferred for further evaluation to an external device, such as the VSE diagnostic electronics from ifm.



Robust: MEMS measuring principle

The VSM101 acceleration sensor is based on a MEMS chip (capacitive measuring principle) and designed for demanding industrial applications. Thanks to MEMS technology, the sensor's proper functioning can be checked actively via the diagnostic electronics (self-test).

Widely compatible: IEPE standard

The sensor transmits its data according to the IEPE signal, which is a standard on the market, e.g. for acceleration sensors. The advantage of IEPE devices is a constantly high sensitivity – irrespective of the type of the connection cable or its length.

Dimensions

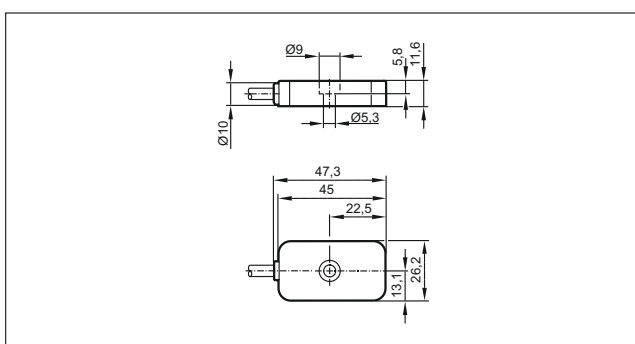







Products

Type	Description	Order no.
	Accelerometer 3 measurement axes	VSM101

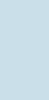
Technical data VSM101		
Operating voltage	[V DC]	13...15
Operating current	[mA]	4...6
Measuring sensitivity	[mV/g]	100
Measuring range	[g]	± 40
Frequency range	[Hz]	0...4500
Ambient temperature	[°C]	-30...85
Protection rating		IP 67, IP 68, IP 69K
Housing material		Stainless steel

Accessories

Type	Description	Order no.
Diagnostic electronics for VSM type acceleration sensor		
	Communication interface: Ethernet protocol: TCP/IP, History memory with real-time clock, Counter function	VSE002
	Communication interface: Ethernet protocol: TCP/IP, History memory with real-time clock, Counter function	VSE100
	Communication interface: Ethernet, Protocol: PROFINET IO Real-time clock	VSE150
	Communication interface: Ethernet, Protocol: EtherNet/IP Real-time clock	VSE151
	Communication interface: Ethernet, Protocol: EtherCAT Real-time clock	VSE152
	Communication interface: Ethernet, Protocol: Modbus TCP Real-time clock	VSE153
Installation		
	Fixing magnet for straight and curved surfaces M5 thread	E30491
	Adhesive adapter for acceleration and vibration sensors, M5 internal thread, stainless steel (303 / 1.4305)	E30475